

VIP-4 INTENSIVITY VACUUM PUMP

AIR CONSUMPTION : 63 lit per min at 4 BAR.
WORKING PRESSURE : 4 BAR.
MAX SUPPLY PRESSURE : 7 BAR.
MAX VACUUM : -0.9 BAR at 4 BAR.
MAX VACUUM FLOW : 165 lit per min.
WORKING TEMP. : -20°C + 100°C.
WEIGHT : 670 g.
NOISE LEVEL : 65 db(A) full flow,
 50 db(A) full vacuum.
MATERIALS : Epoxy painted AL, brass,
 silicon rub, neoprene, stainless steel.

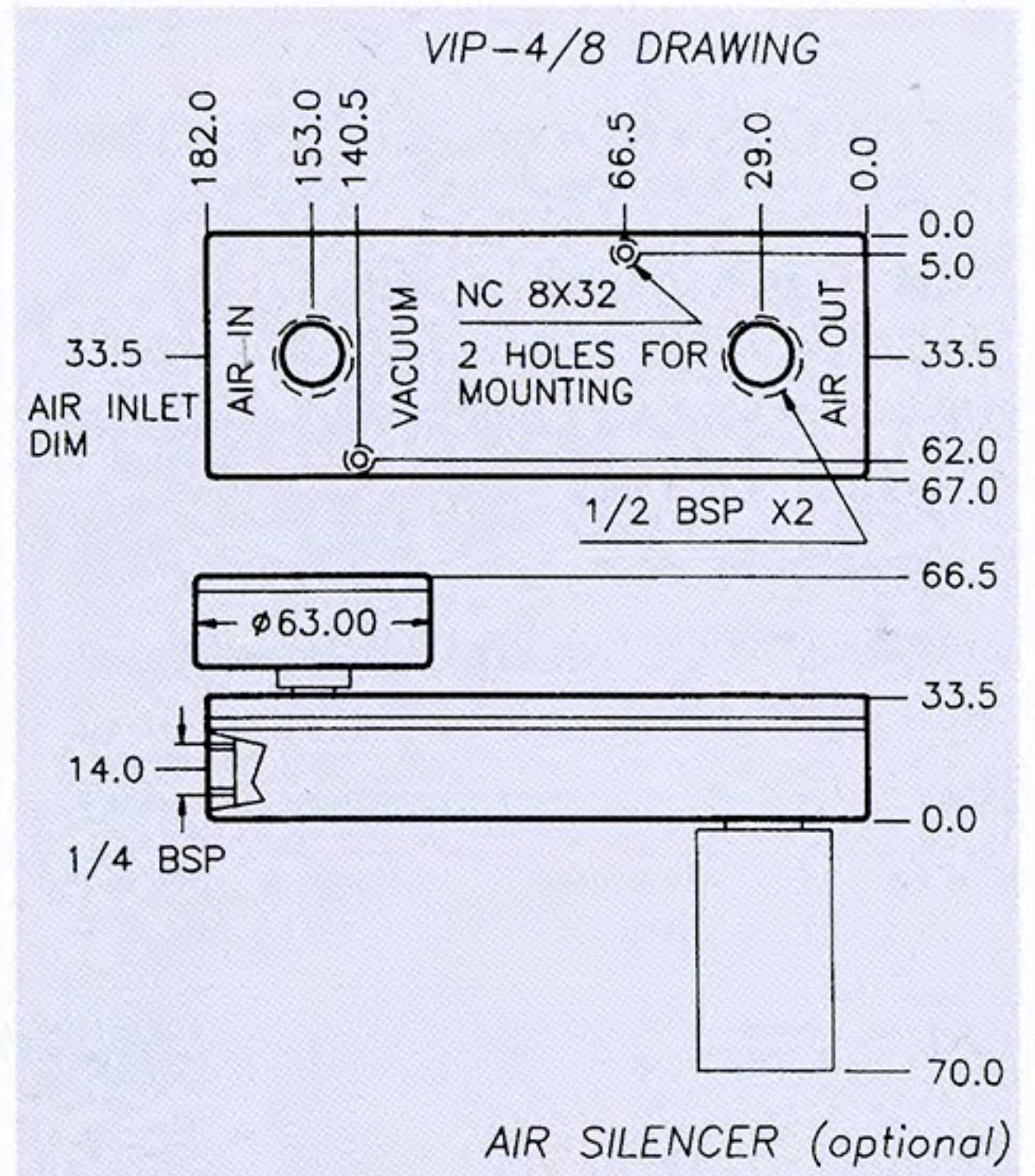

VIP-8 INTENSIVITY VACUUM PUMP

AIR CONSUMPTION : 126 lit per min.
WORKING PRESSURE : 4 BAR.
MAX SUPPLY PRESSURE : 7 BAR.
MAX VACUUM : -0.9 BAR at 4 BAR.
MAX VACUUM FLOW : 320 lit per min.
WORKING TEMP. : -20°C + 100°C.
WEIGHT : 700 g.
NOISE LEVEL : 65 db(A) full flow,
 50 db(A) full vacuum.
MATERIALS : Epoxy painted AL, brass,
 silicon rub, neoprene, stainless steel.

NOTE:

VIP Pumps are often used for handling materials or clamping small parts. They can be used with several suction cups. VIP Pumps flow is higher than VSPs', and its clamping is less sensitive to the cup wear.

vacuum in - BAR	0.1	0.2	0.3	0.4	0.5	0.6	0.7	0.9
time in sec for evacuation of 1 lit to vac' level	VIP - 4 .046	0.16	0.36	0.7	1.2	2	2.8	18
	VIP - 8 .023	0.08	0.18	0.35	0.6	1	1.5	9

vacuum in - BAR	0	0.1	0.2	0.3	0.4	0.6	0.8
induced air in lit per min.	VIP - 4 165	88	51	24	18	9	3
	VIP - 8 320	176	102	48	36	18	6

