

VIP-16 INTENSIVITY VACUUM PUMP

AIR CONSUMPTION : 240 lit per min at 4 BAR.

WORKING PRESSURE : 4 BAR.

MAX SUPPLY PRESSURE : 7 BAR.

MAX VACUUM : -0.9 BAR at 4 BAR

MAX VACUUM FLOW : 900 Nlit per min
at 6 BAR, 700 Nlit per min at 4 BAR

WORKING TEMP. : -20°C + 80°C.

WEIGHT : 2500 g.

NOISE LEVEL : 75 db(A) full flow,
55 db(A) full vacuum.

MATERIALS : Epoxy painted AL, brass,
silicon rub, neoprene, stainless steel.

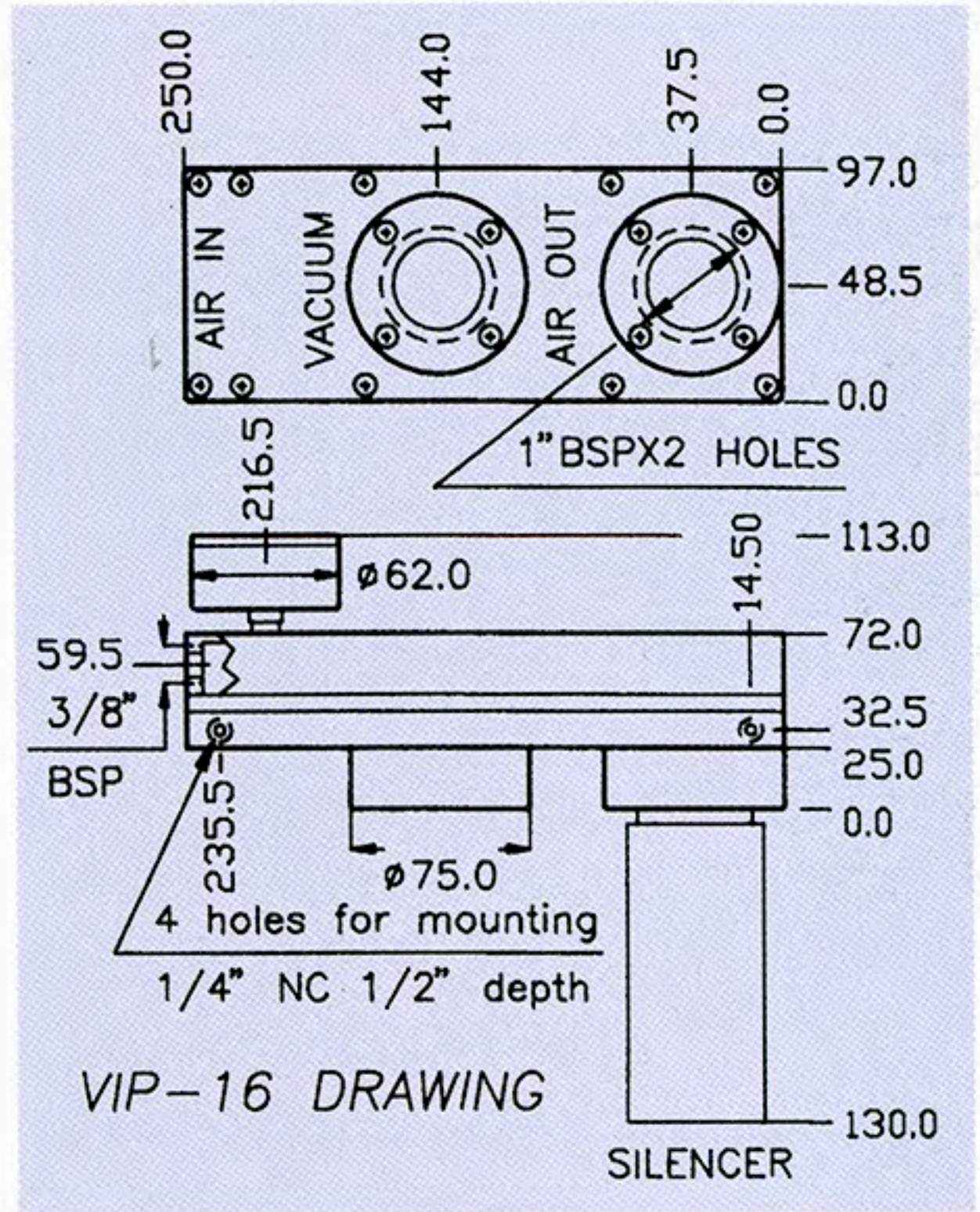

NOTE:

VIP Pumps are often used for handling materials or clamping small parts, When high evacuation flow and deep vacuum is needed. It cuts time for volume evacuation.

AIR AT 4 BAR

vacuum in - BAR	0	0.1	0.2	0.3	0.4	0.5	0.6	0.7	0.9
time in sec for evacuation of 1 lit to vac' level VIP - 16	-	.008	.003	0.08	0.15	0.27	0.5	0.7	4

vacuum in - BAR	0	0.1	0.2	0.3	0.4	0.5	0.6	0.7	0.8
induced air in lit per min. VIP - 16	700	480	240	108	58	50	40	26	13

