

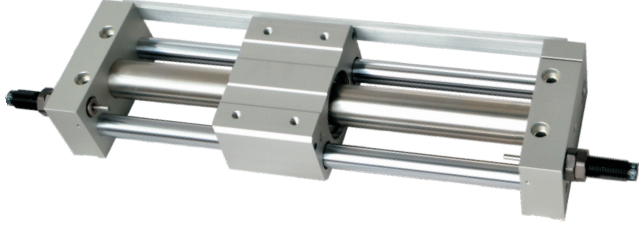

Rodless magnetic cylinder(With guide)——RMT Series

Product series

Series name	Acting type	Bore size	Collocation of sensor switch	
			CS1-G	DS1-G
RMT Series 	Double acting	16		
		20		
		25	●	●
		32		
		40		
Page	364		403	

Installation and application

1. Dirty substances in the pipe must be eliminated before cylinder is connected with pipeline to prevent the entrance of impurities into the cylinder.
2. The medium used by cylinder shall be filtered to 40 μ m or below.
3. Anti-freezing measure shall be adopted under low temperature environment to prevent moisture freezing.
4. If the cylinder is dismantled and stored for a long time, pay attention to conduct anti-rust treatment to the surface.
Anti-dust caps shall be added in air inlet and outlet ports.



RMT

Rodless magnetic cylinder(With guide)

RMT Series

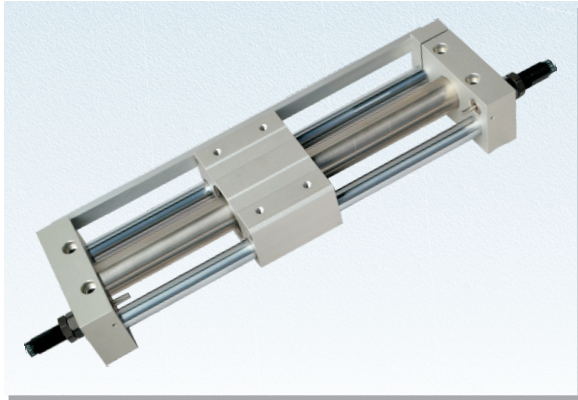

Specification

Bore size (mm)	16	20	25	32	40
Acting type	Double acting				
Fluid	Air(to be filtered by 40 μ m filter element)				
Operating pressure	0.18~0.7MPa(28~100psi)(1.8~7bar)				
Proof pressure	1.0MPa(145psi)(10.0bar)				
Temperature (°C)	-10~60				
Speed range (mm/s)	50~400				
Stroke tolerance (mm)	0~250 ^{+1.0} ₀ 251~1000 ^{+1.4} ₀ 1001~ ^{+1.8} ₀				
Cushion type	Fixed cushion Shock absorber(Available)				
Safe holding force (N)	140	200	320	550	850
Port size ①	M5 × 0.8		1/8"		1/4"

① PT thread、NPT and G thread are available. Add) Refer to P403~426 for detail of sensor switch.

Stroke

Bore size (mm)	Standard stroke (mm)																Max. stroke(mm)
16	50	100	150	200	250	300	350	400	450	500	600	700	750	800	750		
20	50	100	150	200	250	300	350	400	450	500	600	700	750	800	1000		
25	50	100	150	200	250	300	350	400	450	500	600	700	750	800	1500		
32	50	100	150	200	250	300	350	400	450	500	600	700	750	800	1500		
40	50	100	150	200	250	300	350	400	450	500	600	700	750	800	900	1000	1500

Note) Consult us for non-standard stroke.

Symbol

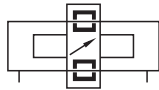

Product feature

1. This magnetic cylinder is basically a pneumatic rodless cylinder featuring a mobile piston fitted with annular magnets. The mobile carriage is also equipped with magnets to provide magnetic coupling (carriage/piston). The carriage slide freely along the main tube.
2. It is dust-proof as the isolation between the carriage and piston.
3. It is compact in space.
4. The non adjustable rubber bumpers and the adjustable pneumatic cushioning on both ends of the cylinder ensure the smooth action. if shock absorber be used, the cushioning effect is more perfection.
5. Double guides ensure high precision and can endure proper side load or prejudicial load.

Ordering code

Model can to be changed Ordering code. Example:

Production type: RMT
 Bore size: 20mm
 Stroke: 100mm
 Magnet: With magnet
 Cushion type: With two shock absorber
 Thread type: NPT

Model: RMT20 × 100-S-A-T

Ordering code: RMT 20 S 0100 A T

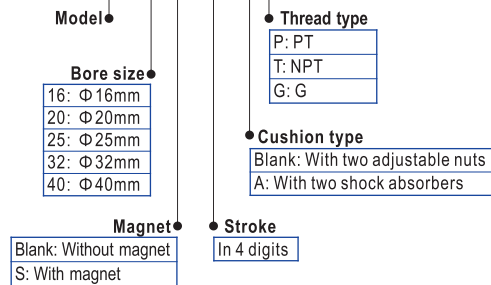

Explain of model

RMT -20 × 100 - □ - □ - P

Model
 RMT: Rodless magnetic cylinder(With guide)

Bore size
 16, 20, 25, 32, 40

Stroke
 Refer to stroke table for details

Magnet
 Blank: Without magnet S: With magnet

Thread type
 P: PT
 T: NPT
 G: G

Cushion type
 Blank: With two adjustable nuts
 A: With two shock absorbers

Remark:

① Blank on thread code means metric M thread. There is only metric thread for Φ16. If G or NPT thread is needed, please comment.

Mounting type

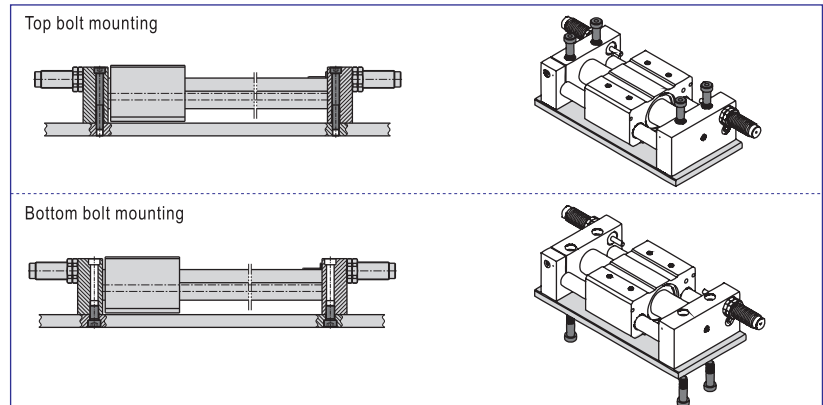

Rodless magnetic cylinder(With guide)

RMT Series

Installation and application

1. How to determine load:

1.1) The maxi load to move must be less than the theoretical holding force.

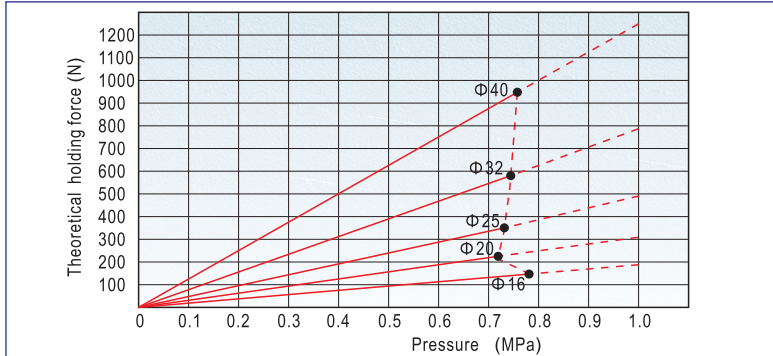

1.2) The relation between loading and stroke as below (Loading center and slide table center must be superposition)

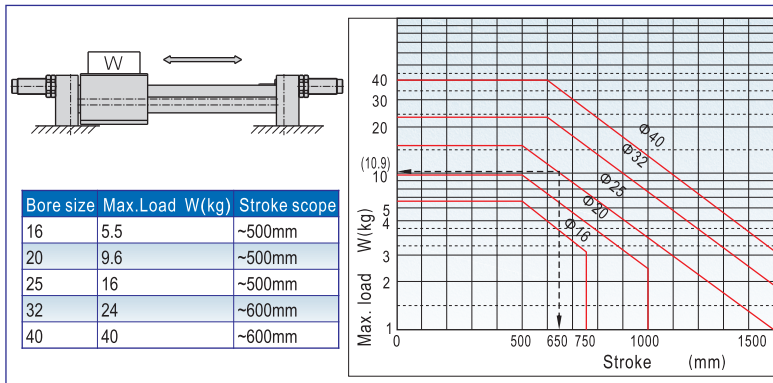

1.3) You should keep the loading center and the slide table center be superposition, if not you can calculate the load as below method.

First you should calculate the applied load coefficient(σ):

Example) Bore size: 25mm, Stroke: 650mm

- (1) Max. Load=16kg
- (2) When stroke=650mm, the allowable load=10.9kg
- (3) $\sigma = 10.9/16 = 0.68$

Note) When bore size is Φ16 and stroke is 500mm, or bore size is Φ20 and stroke is 500mm, or bore size is Φ25 and stroke is 500mm, or bore size is Φ32 and stroke is 600mm, or bore size is Φ40 and stroke is 600mm, the $\sigma = 1$.

1.3.1) Horizontal acting (Vertical mounting):

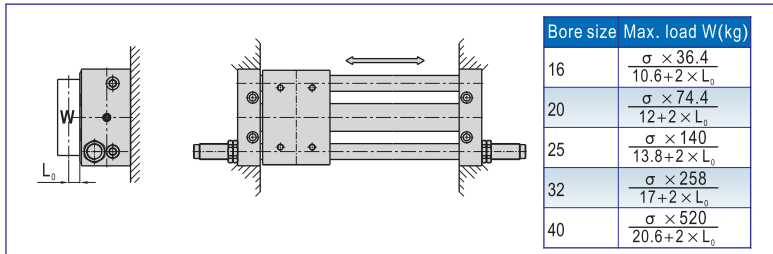

1.3.2) Horizontal acting (Loading center and slide table center offset):

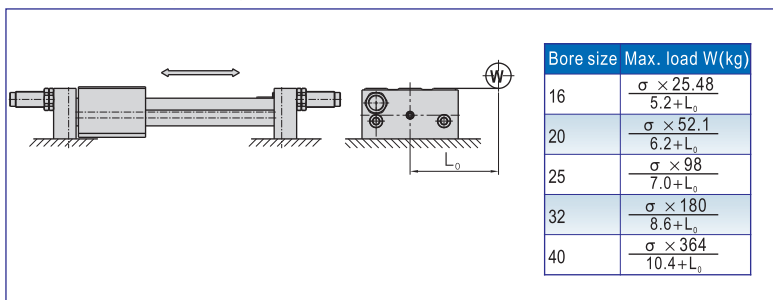

1.3.3) Horizontal acting (Loading barycenter and acting direction is coplanar. Loading center and slide table center offset):

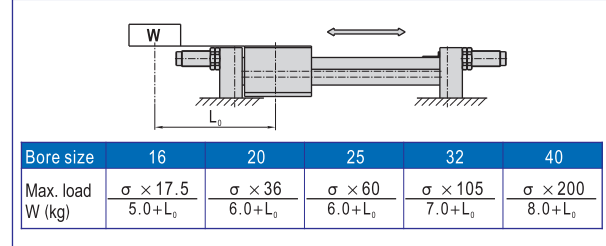

1.3.4) Incline acting (Acting direction and barycenter is vertical):

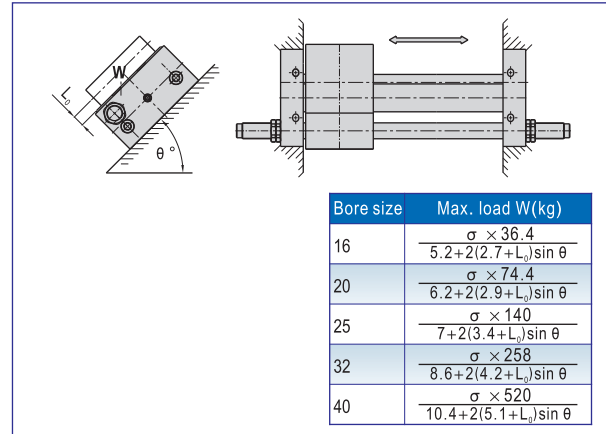

1.3.5) Incline acting (Acting direction):

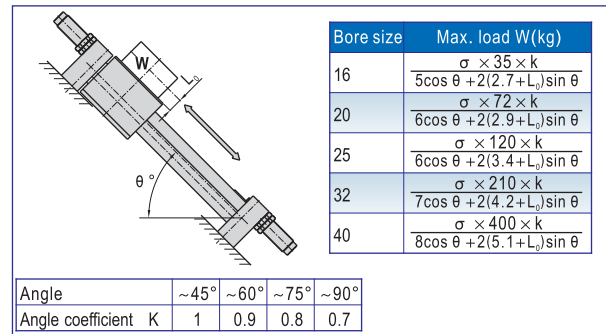

1.3.6) Horizontal acting (Loading offset):

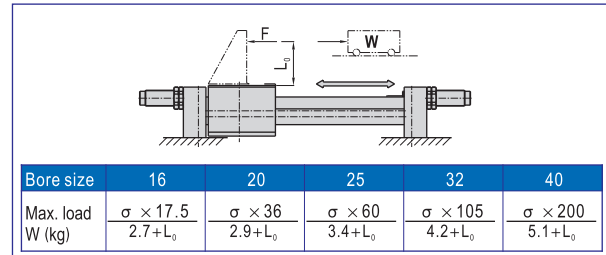

1.3.7) Vertical acting:

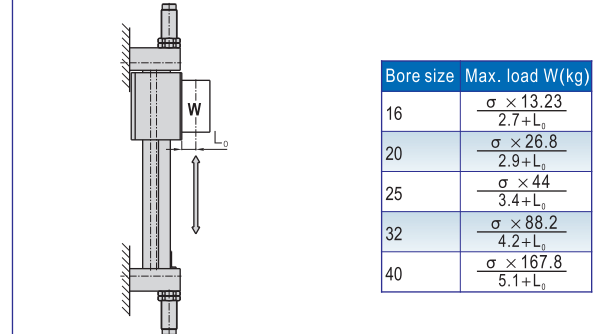

Rodless magnetic cylinder(With guide)



RMT Series

2. About shock absorber
- 2.1) Shock absorbers are consumable parts. When a decrease in energy absorption capacity is noticed, it must be replaced. Refer to the table below for shock absorber type.
 - 2.2) Never loosen the bottom screw of the shock absorber. (It is not an adjustment screw.) That may cause oil leakage.
 - 2.3) Refer to the table below for tightening torques of the shock absorber setting nut.

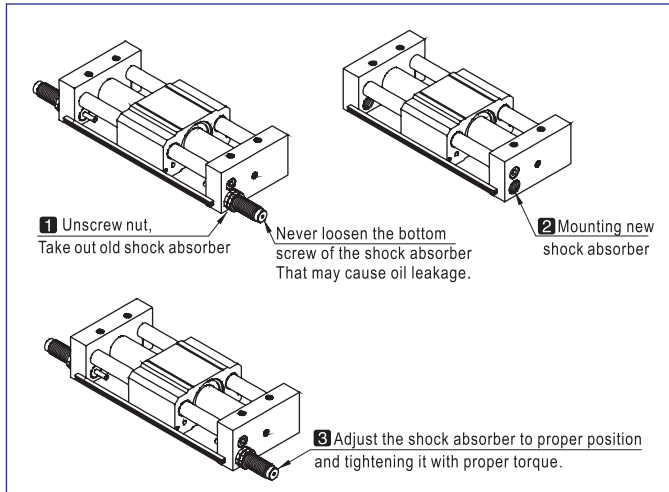

Cylinder model	RMT16	RMT20	RMT25	RMT32	RMT40
Shock absorber type	ACA1006-A	ACA1007-1N	ACA1412-1N	ACA2020-1N	ACA2020-1N
Tightening torque(Nm)	1.67	1.67	3.14	10.80	10.80

3. About sensor switch
- 3.1) Sensor switch only can be used for the cylinder with magnet. The magnet located the four corner of body's(refer below). The cylinder with magnet have both group mounting hole for mounting rail. please refer to below for ordering sensor switch, mounting it into the rail's groove, adjusting it to proper position, tightening it with proper torque.

Cylinder model	RMT16	RMT20	RMT25	RMT32	RMT40
Sensor switch	CS1-G, CS1-GX, DS1-G, DS1-GN, DS1-GP				

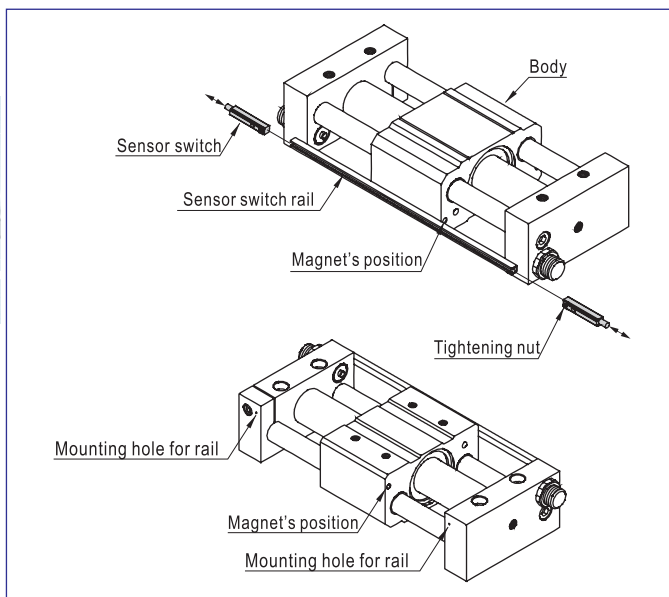

Add) Refer to Page 420, 430 for detail of sensor switch.

Inner structure and material of major parts

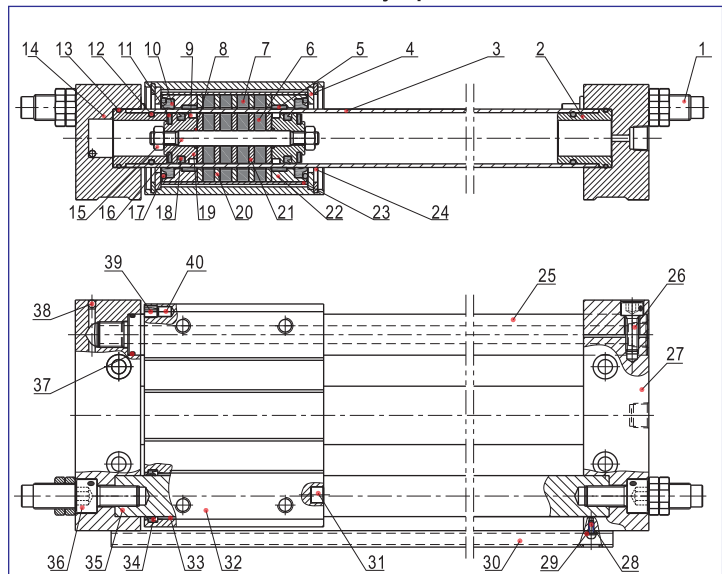

NO.	Item	Material	NO.	Item	Material
1	Shock absorber	Combination	21	Magnet washer	Carbon steel
2	Washer cover	Aluminum alloy	22	End cover	Aluminum alloy
3	Stainless steel barrel	Stainless steel	23	Mobility iron	Aluminum alloy
4	Washer	Carbon steel	24	C clip	Spring steel
5	Wearing ring	Wear resistant material	25	Guide I	Carbon steel
6	Magnet	Rare-earth material	26	Countersink screw	Carbon steel
7	Magnet	Rare-earth material	27	Fixing plate	Aluminum alloy
8	O-ring	NBR	28	Screw	Carbon steel
9	Wear ring	Wear resistant material	29	Spring washer	Spring steel
10	Scraping dust ring	Plastics	30	Rail	Aluminum alloy
11	Bumper	NBR	31	Bumper block	Stainless steel
12	O-ring	NBR	32	Barrel	Aluminum alloy
13	O-ring	NBR	33	Bushing	Bronze+Fill lubricant
14	Fixing plate	Aluminum alloy	34	Gasket	TPU
15	Nut	SS41	35	Guide II	Carbon steel
16	Joint pole	Stainless steel	36	Countersink screw	Carbon steel
17	O-ring	NBR	37	O-ring	NBR
18	Piston seal	TPU	38	Steel ball	Stainless steel
19	Magnet	Aluminum alloy	39	Magnet	Rare-earth material
20	Magnet washer	Carbon steel	40	Location washer	NBR

RMT



Rodless magnetic cylinder(With guide)



RMT Series

Dimensions

RMT-A

RMT

Bore size\Item	QW	Q	Z	PA	PB	L	W	TT	T	MM	B	C	G1
16	30	75	107	30	50	60	72	22.5	22.5	M5 × 0.8 Dp:10	9.5	5	6.5
20	38	90	124	40	70	70	87	25.5	25.5	M6 × 1.0 Dp:10	9.5	5.2	8.5
25	42	90	124	40	70	70	97	25.5	25.5	M6 × 1.0 Dp:10	11	6.5	8.5
32	50	110	148	40	75	85	119	28.5	28.5	M8 × 1.25 Dp:12	14	8	9.5
40	64	120	170	65	105	95	142	35.5	35.5	M8 × 1.25 Dp:12	14	8	10.5

Bore size\Item	G2	H	HP	PW	GP	LD	D	d	(N1)	(N2)	JK	P
16	6.5	40	39	75	52	5.2	18	12	15.5	8.5	M6 × 1.0 Dp:9.5	M5 × 0.8
20	8.5	46	45	90	63	5.2	22.8	16	22.5	10.5	M6 × 1.0 Dp:9.5	1/8"
25	8.5	54	53	100	70	7	27.8	16	40.5	11.5	M8 × 1.25 Dp:10	1/8"
32	9.5	66	64	122	86	8.7	35	20	57.5	17.5	M10 × 1.5 Dp:15	1/8"
40	10.5	76	74	145	105	8.7	43	25	50.5	10.5	M10 × 1.5 Dp:15	1/4"



RMT

Memo

Note



RMT